

System B - Back bolted stone curtain wall

Installation Standards

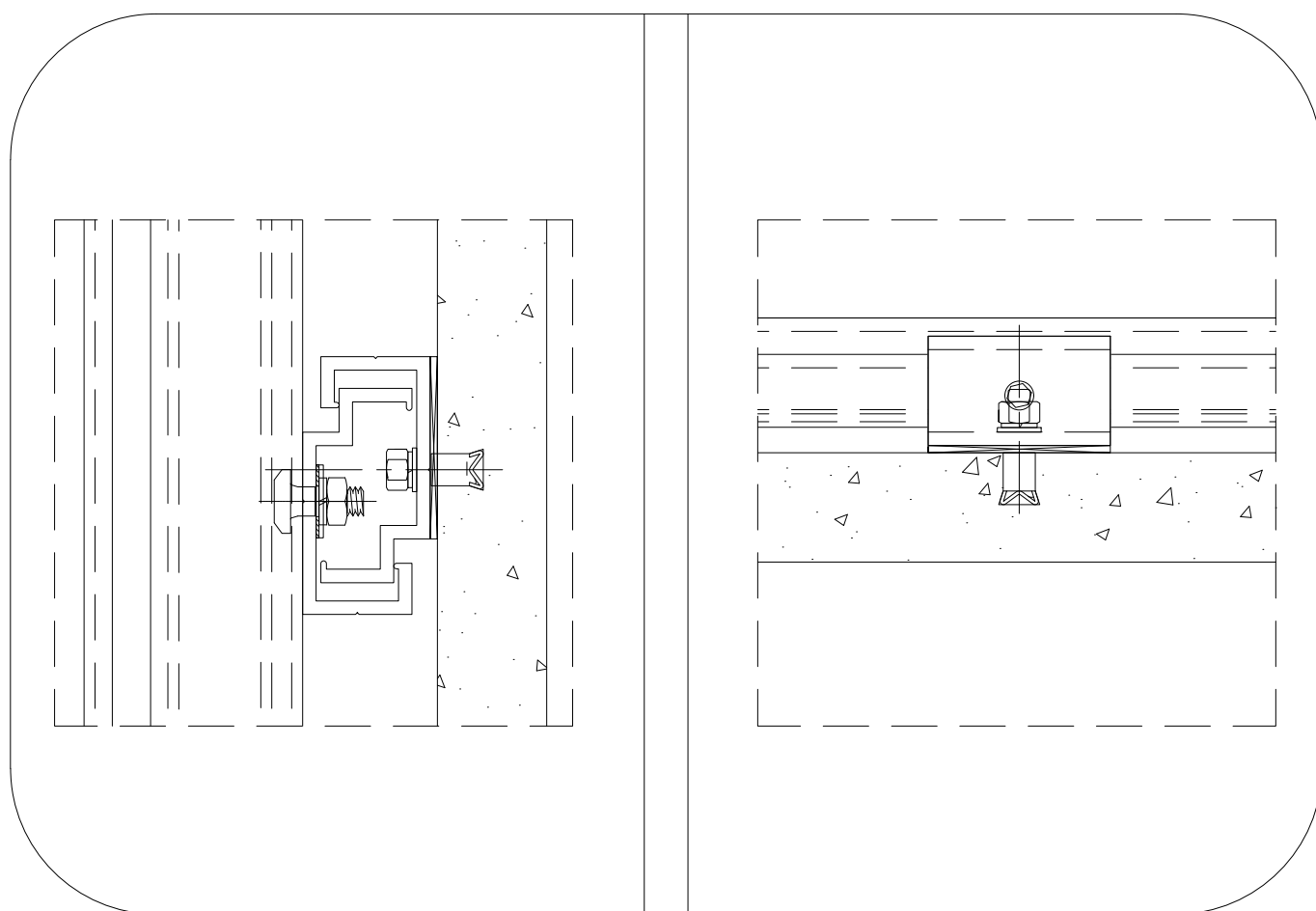

上海福发实业有限公司

SHANGHAI FUFA INDUSTRIAL CO., LTD.

01. Measuring and placing lines.....	1-1
02. Installation standards for column connectors.....	2-1
03.the curtain wall column installation standards	3-2
04. Standards for the installation of external finishes	4-1

1. Baseline calibration

Before using the benchmark points or reference axes provided by the general contractor, re-measurement should be conducted. The angular closure error, relative error of side lengths, and elevation closure error should all fall within the permissible error range. The benchmarks can only be used after passing re-measurement verification.

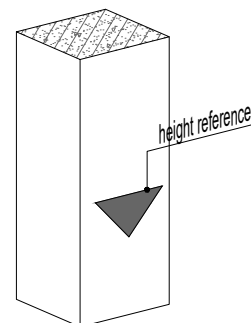
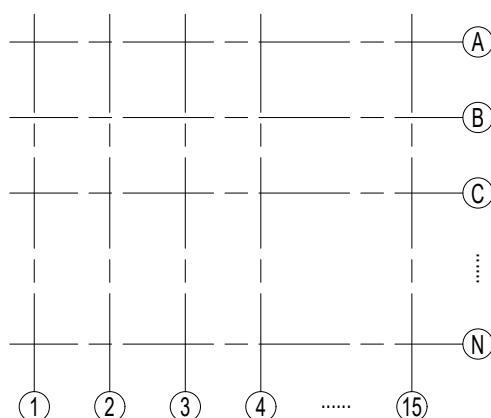

2. Survey Control Network

- To achieve overall control and localized measurements for the exterior curtain wall system, a construction survey control network should be established within the measurement system. The control network should be straightforward and clear to meet construction requirements. According to the drawings and curtain wall construction specifications, a three-level control point system will be adopted: peripheral primary control points, approach control points, and curtain wall system control points.
- Peripheral Primary Control Points These control points are positioned outside the building and consist of multiple primary points surrounding the structure. Their main functions are to control approach sub-control points and internal system control points, provide initial data for the control network, and allow for the measurement of locations that are difficult to assess from other control points. They can also serve as benchmarks for as-built surveys and deformation monitoring after project completion. To ensure long-term stability, concrete observation piles should be established. Additionally, measurement control points set by the civil engineering unit may also be used as peripheral control points.
- Approach Control Points These secondary control points are positioned around the main building and should be placed as close to the edge of the curtain wall system as possible to facilitate establishing a network of system control points. A coordinate grid pattern formed by the building's longitudinal and transverse axes is proposed. The expected positional accuracy relative to primary control points is $\pm 2\text{mm}$, with a relative accuracy between adjacent points of $\pm 1.5\text{mm}$, providing a benchmark for the curtain wall system control points.
- Curtain Wall System Control Points: These are control points set on the curtain wall system itself, serving as reference points during the construction of the curtain wall system. Using the secondary control points as benchmarks, curtain wall system control points are measured and established layer by layer, ensuring accurate positioning for the installation of each section of the curtain wall.
- Elevation Control Point Setup: Use the elevation benchmarks provided by the general contractor, applying them after calibration. As installation progresses, transfer these elevation points upwards to each floor to serve as the reference for elevation measurements on each level.

3. Measurement of the Main Civil Structure

- Before the installation of the curtain wall, the measurement of the main civil structure should be conducted. If, during the measurement process, it is found that the construction error of the main structure exceeds the permissible deviation for the installation of the exterior finishing works, or if adjustments cannot be made due to the structural conditions of the curtain wall system, it is essential to promptly communicate with the civil engineering unit and the owner to discuss and find a solution together.
- Verify the accuracy of the civil structure elevation lines: Using the ± 0.000 elevation and axes provided by the civil engineering unit as benchmarks, utilize a level, theodolite, laser total station, 50-meter long tape measure, and plumb bob to check the accuracy of each floor's elevation in the civil structure, while also calibrating the correctness of the benchmark axes.
- Measurement Methods for Height, Levelness, and Vertical Lines: Using a level with the ± 0.000 benchmark, measure the flatness of the perimeter edges on each floor. Employ a leveling rod and level to determine the horizontal levelness of each connection piece. For the exterior facade of each floor, suspend a 20 kg weight from a 50-meter steel tape measure fixed at multiple levels. After allowing it to settle, use the equal height method to measure and calculate the actual elevation of each floor and the total height of the building structure. Height marks should be recorded with paint at the same position on the columns or structures. These height marks must be protected from being erased or damaged before the curtain wall installation is complete. The measurement error for elevation should be: between floors $\leq \pm 3\text{mm}$, total elevation $\leq \pm 20\text{mm}$. For the vertical direction, use a plumb bob positioned at the benchmark axis to measure the deviation of the floor slabs and determine the control line. The instruments used include a laser theodolite, level, plumb bob, measuring tape, and spring scale.

- If the elevation of civil engineering is found to be inaccurate, another mark should be made, and there should be a mark of "special for curtain wall", and the review situation should be reported to the general contracting unit and the supervisor.
- Review of the closure of civil datums and lines

According to the relationship between the axes of the building structure and the outer diameter size calibrated in the design drawings, the horizontal and vertical dials of the latitude and longitude instrument are used to determine the rectangular datum control network and the distance of the connecting lines of the same vertical plane of the control curtain wall unit, and the vertical error between the datums is controlled within the projection range of 5mm in diameter, and the direct distance error of the connecting lines of the datums is not more than 3mm. The structural contour line is put out on the basis of the reference control network to determine the degree of deviation between the actual size of the building structure and the design size, and for the structural area which is larger or smaller than the design deviation requirement, the structural construction unit will carry out repair and then deliver it to us for acceptance and use. The contour line is the only correct indication that the dimensions of the entire structure comply with the design requirements, so it must be protected from being eliminated or overwritten.

4. Wire release process

- Based on the measurements of the main body of the civil construction, the axes were released one by one from the bottom of the curtain wall.
- In each axis between the release of the compartmentalised line, such as the need to hang vertical steel line, attention should be paid to check the drawings in order to avoid the construction of hanging line and other objects to interfere.
- Axis transfer from the previous floor with a warp beam and wire drop.
- An axis control line is selected for elevation transfer.
- Self-inspection of the released compartmentalisation line and elevation control line of each layer, and report to the general contractor and supervisor for acceptance after passing the self-inspection.

5. Measurement and release tools

Latitude and longitude meter (total station if available or necessary), level, line cord, plumb bob, steel tape measure, etc.

6. Quality assurance measures

- Instruments, steel rulers and tape measures used must be tested and approved before use.
- After the completion of each axis line release, it must be double-checked for accuracy before proceeding with the release of each compartment line.
- After the completion of the release line, timely request the general contractor, supervision re-inspection, and make a good record.

Pre-embedded parts testing and cleaning

1. Clean up layer by layer and section by section according to the results of measuring and placing lines and the embedded parts map. Requirements for the surface of the buried parts must be clean, the outer surface must be exposed to the main body. Clean up should be avoided up and down cross work, can not be avoided should be set up when the protective shed. Cutting must be added below the protective plate, so as to avoid the residue, tools fall. A small amount of residue falling to the ground should be cleaned up in time.
2. After the completion of the clean-up of the buried parts for verification, size deviation is large, reported to the general contractor, the supervision agreed to deal with. Generally use the same thickness and material with the buried pieces of equal strength steel plate welding, weld for continuous corner welding, deviation is too large, the other side of the need to add a chemical anchor bolt or a reliable connection to fix, plus should be communicated with the designers, and through the structural calculations of the calibration.
3. The parts without buried parts need to be installed on site. Installation must be based on the results of measurement and placement, accurate positioning. Axis size, horizontal elevation must be in line with the design and acceptance specification requirements. The surface of buried parts must be flat. The installation should be fixed by penetrating bolts or chemical anchor bolts that meet the requirements of design and relevant regulations.
4. The outside of the buried plate of the flat embedded parts may be covered by the mortar flowing during pouring, and the surface of the embedded plate should be cleaned up before the curtain wall frame is erected.

Installation of rear connectors

1. When the anchor bolts of the back-embedded parts are not all placed inside the embedded plate due to the reinforcement, the distance from the centre to the edge of the embedded plate shall not be more than 50mm, and the embedded plate shall be padded and welded firmly by the auxiliary pressure plate with a thickness of not less than 8mm.

As illustrated in the diagram.

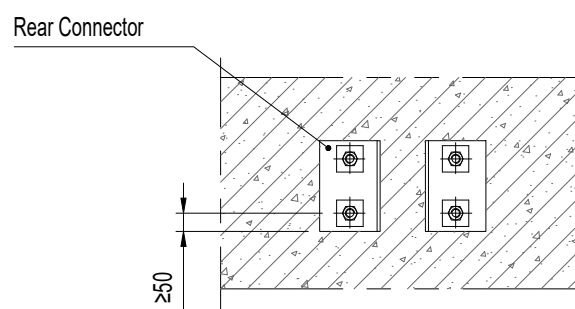

2. Pre-embedded parts cleaning and testing, post connection installation and inspection standards

2.The minimum spacing value S_{min} and the minimum margin value C_{min} of group anchor bolts should be given by the manufacturer through the inspection and analysis of the state–authorised testing organisations, otherwise it should not be less than the following values: (of which d_{nom} is the outer diameter of the anchor bolts).

- Backward expanding ground anchor bolt: $S_{min} \geq 10d_{nom}$; $C_{min} \geq 12d_{nom}$;

3.The thickness h of the concrete substrate shall fulfil the following provisions:

- For backward expanding ground anchors and expanding type anchors, $h \geq 1.5L \geq 100$ mm.

Note: Where L is the burial depth of the anchor bolt and d is the diameter of the anchor hole.

4.The effective anchoring depth L of the anchor bolts does not include the decorative and plastering layers. Anchor bolts shall not be arranged in the protective layer of concrete.

5.Chemical reinforcement installation should be drilled according to the design anchorage depth, hole diameter $D = d + (4 \sim 10)$ mm.

6.Anchor holes should meet the requirements of the design or product installation instructions. When there is no specific requirement, it should be in accordance with the relevant provisions of the Technical Regulations for Post–anchoring of Concrete Structures.

7.The hole should be cleared thoroughly, for the anchor hole of expansion type anchor bolt, the hole should be blown thoroughly with air compressor or manual air cylinder to clean the crumbs and dust in the hole.

8.The glue should be tested and rechecked on site before use, the glue should be weighed accurately, the mixing should be uniform, and the filling should be full.

9.Anchor holes should avoid the main force tendons, for the waste holes, should be filled with chemical anchoring adhesive or high strength grade resin cement mortar.

10.Post–connectors need to be pulled out on site according to specifications to verify that the design and construction meet the requirements for use.

Installation Inspection Standards

Installation Inspection Standards for Embedded Parts and Post Connectors		
sports event	element	quality requirements
embedded part	Position size deviation	± 20 mm
	Unevenness with theoretical wall surface	± 10 mm
	Pre-embedded parts cleaned surface and grooves free of impurities	
	Pre-embedded parts not protected against corrosion are retrofitted with a corrosion protection layer.	
Rear Connector	Position size deviation	± 20 mm
	Unevenness with theoretical wall surface	± 10 mm
	Clearance to wall	≤ 5 mm
	Expansion bolt drilling depth (greater than expansion bolt length)	≤ 10 mm
	Length of Expansion Pipe Exposed to Wall Surface	≤ 5 mm
	Expansion bolt drilling diameter deviation	$0 \sim +0.5$ mm
	Expansion bolt size from concrete edge	≥ 50 mm
	Distance between bolt head and nut after tightening	≤ 30 mm
	Nut and bolt spot welding not less than 2 points	
	The fastening form of the penetration bolts is in accordance with the design requirements and in the same direction.	
	Exposed threads not less than 2 pitches after tightening of penetration bolts	
	Complete set of spare parts for bolts	
	Square shims in the same direction	
	Whether the use of auxiliary pressure plate is in line with the specifications (allowing two bolts to be hit on the outside of the embedded parts, the distance (allowing from the centre to the edge of the embedded parts ≤ 30 mm, through the thickness of the auxiliary pressureplate of not less than 8mm and the embedded partswelded firmly)	

3. Curtain wall frames and inspection standards

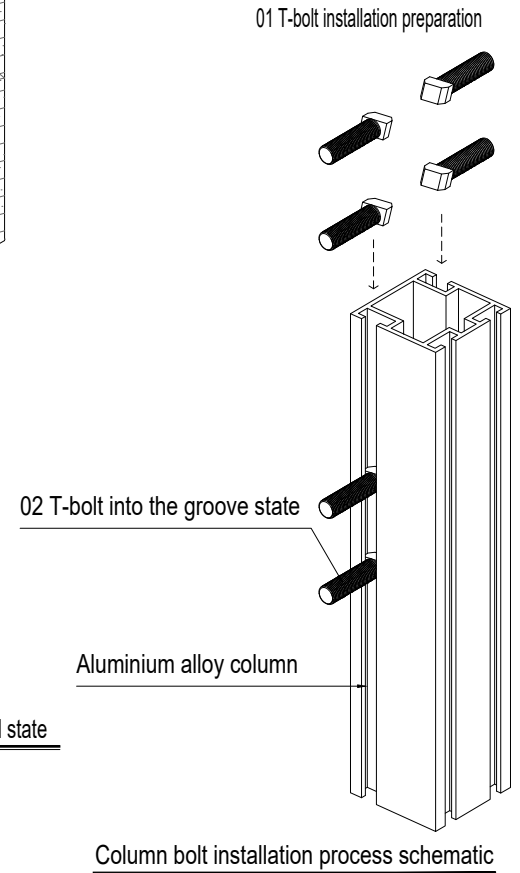
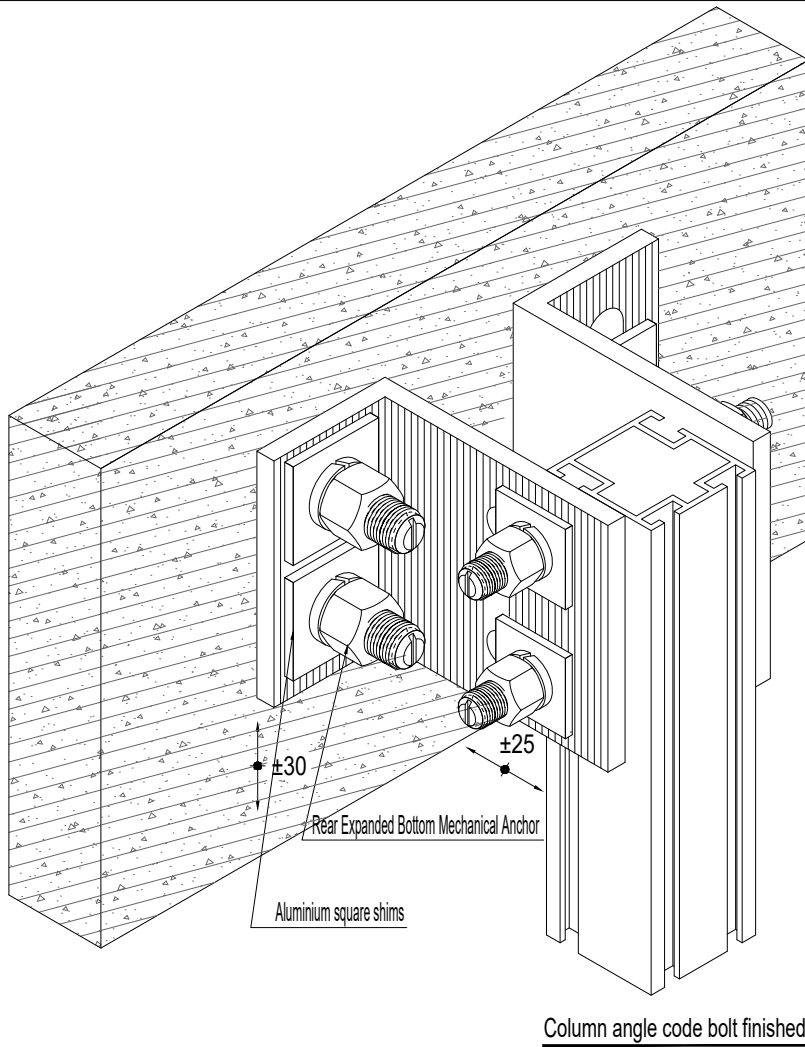

Installation error:

1. the column installation elevation deviation should not be greater than 3mm;
2. The deviation of the axis before and after should not be greater than 2mm, and the deviation of the left and right should not be greater than 3mm;
3. two adjacent vertical frame installation elevation difference should not be greater than 3mm.
4. Maximum difference in elevation of columns on the same floor should not be more than 5mm;
5. The permissible deviation of the distance between two adjacent vertical frames' fixing points is 2mm.

Vertical frame datum alignment

Horizontal transverse positioning of vertical frames

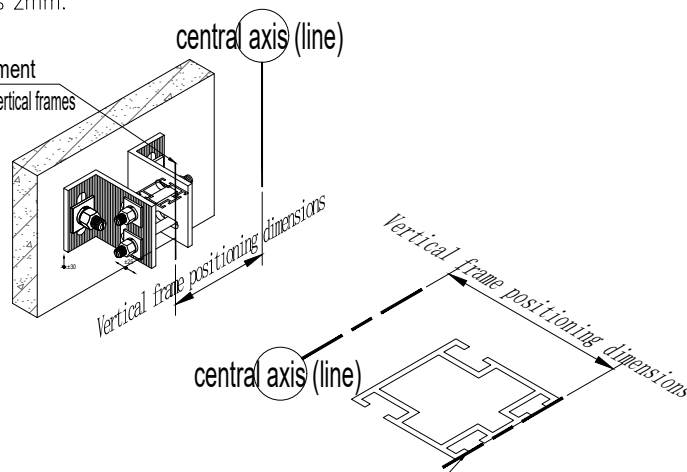

Vertical frame datum alignment

Horizontal in/out positioning of vertical frames

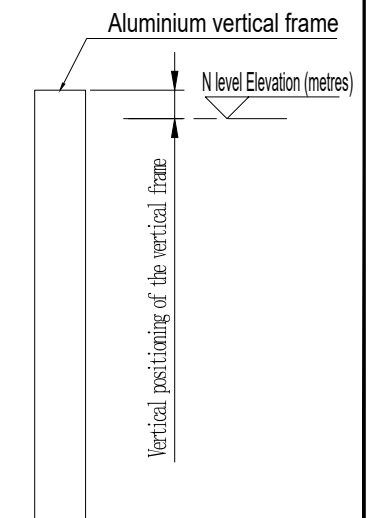

3. Curtain wall frames and inspection standards

vertical or horizontal frame connection

Form I: Horizontal frame on the outside of the vertical frame

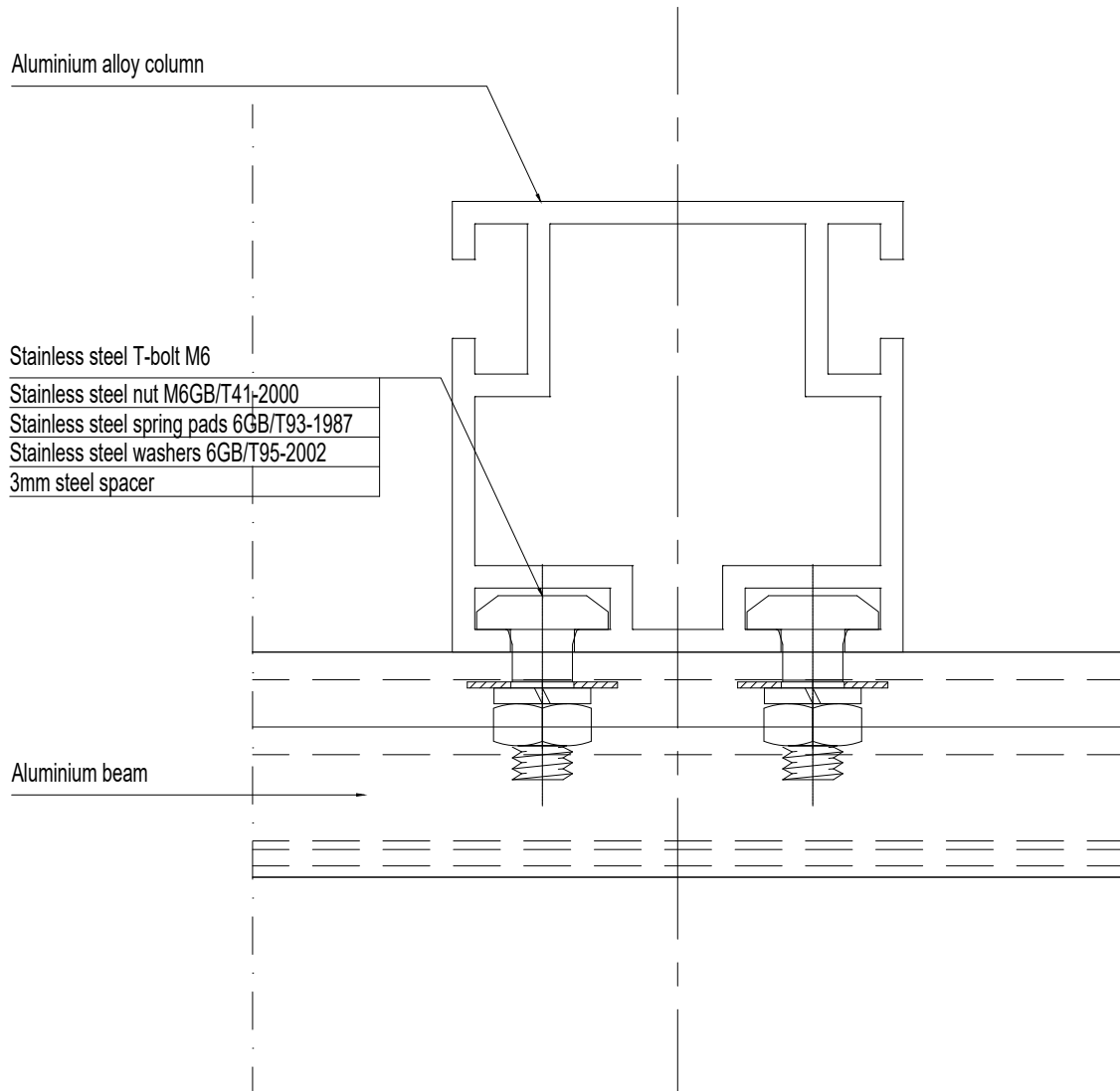

4. Standards for the installation of external finishes

Horizontal and vertical frames connected to stone pendants

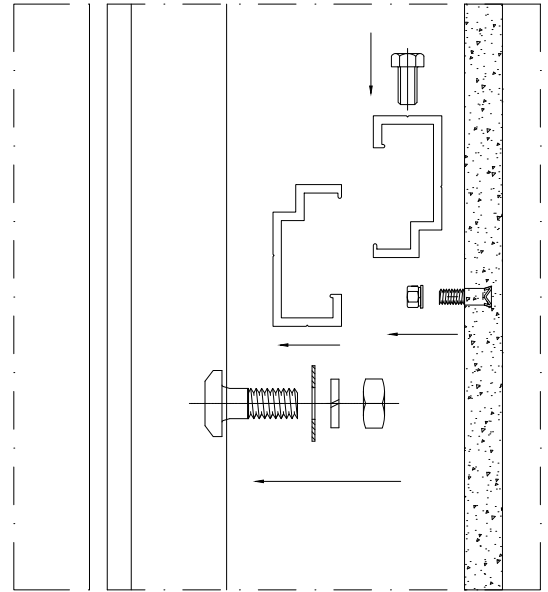
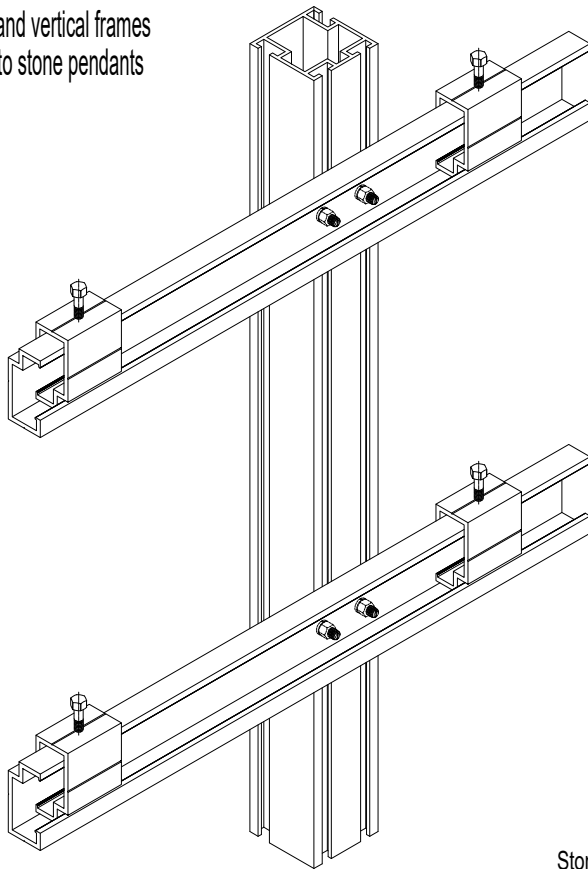

Installation of stone pendant 2D schematic diagram

Installation of stone pendants

Stone slab edge line schematic

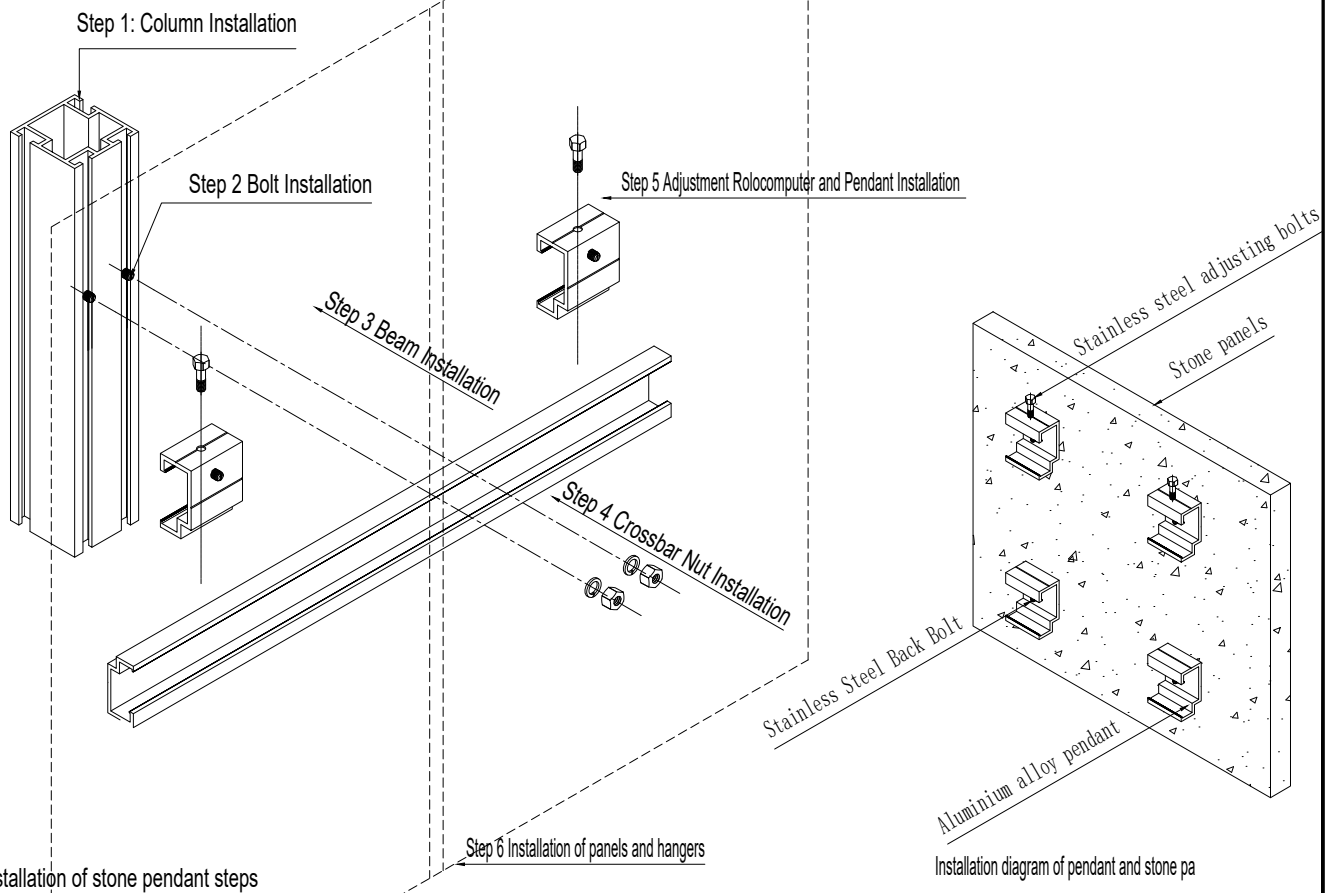

Installation of stone pendant steps

Step 6 Installation of panels and hangers

Installation diagram of pendant and stone pa